

USER'S MANUAL - UNIVERSAL ELECTRONIC WEEK TEMPERATURE CONTROLLER

Characteristics of the universal electronic week temperature controller

The universal electronic week temperature controller allows you to program up to 9 time intervals per day and the temperature according to your preferences. The temperature controller allows operation in the following three modes:

- FLOOR - control of underfloor heating,
- ROOM - control of room temperature,
- LIMITER - room temperature controller with limiter.

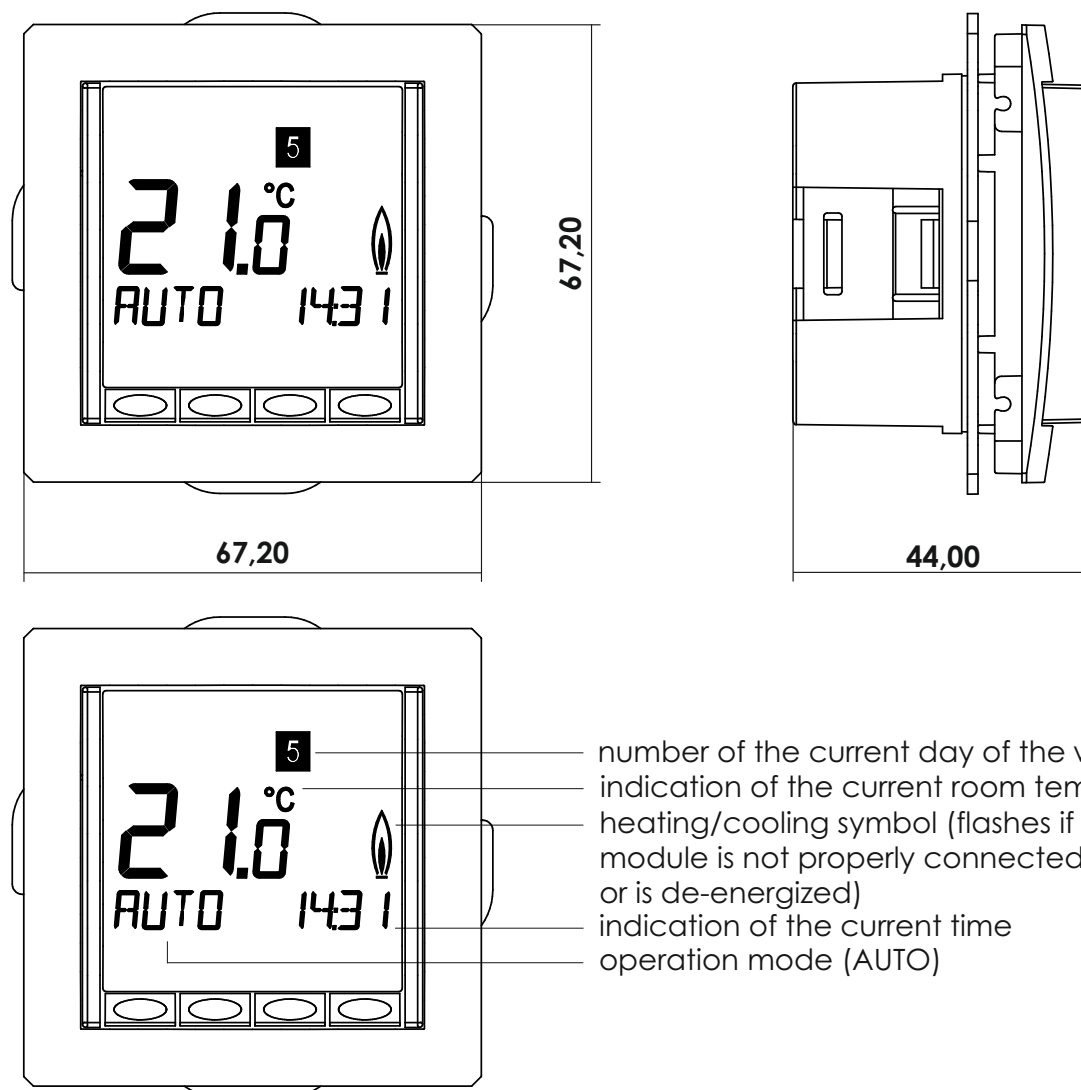

Warranty terms

The warranty is provided for a period of 12 months from the date of purchase. The defective controller, together with the proof of purchase, shall be delivered to the manufacturer or to the dealer. The warranty does not cover fuse replacement, mechanical damage, defects resulting from self-repair and improper use of the product.

The warranty period is extended by the duration of the repair.

Notice! Protection class of the shield

The installation must be carried out by a qualified person at de-energized voltage and must comply with national safety standards. In order to maintain Class II protection, the user must be prevented from accessing the rear parts of the installation. The mechanism is designed to adjust the temperature only in dry rooms under standard ambient conditions. The controller meets the requirements of EN 60730. It is an "independently installed device" operating according to the way 1C works.

Technical data

Symbol	...DRT-3.1, ...DRT-3.2
Supply voltage	230 V AC 50 Hz (195-253 V)
Temperature setting range	5 °C-30 °C; at intervals of 0.5 °C
Temperature control at intervals of	0,1 °C
Relay	output, 230 V
Connection current	10mA... 16(4)A*; 230 V~
Output signal	PWM or ON/OFF pulse width modulation
PWM time intervals	adjustable
Hysteresis	adjustable
Shortest time interval: 10 minutes	10 minutes
Power consumption	~ 1,2 W
Accuracy of the clock	< 4 minutes / year
Memory maintaining by battery	~ 10 years
Probe (optional)	SO-1, length 4 m, can be extended to 50 m
Ambient temperature:	
- when operating	0°C - 40°C (without humidity)
- when storing	-20 °C - 70 °C (without humidity)
Rated surge voltage	4 kV
Testing temperature of the head	115 °C
Voltage and current for interference measurements	230 V, 0,1A
Protection grade	IP 30
Shield protection class	II (see: "Warning! Protection class of the shield")
Software class	A
Degree of contamination	2
Dimensions with outer frame	90,20 x 90,20 x 44,00 mm

*under current > 14A, N - wire must not be connected to the controller, only directly connected

Battery

A CR 2032 battery is included with the temperature controller, which allows the controller to be programmed without being plugged in. If the battery is depleted and the controller is unplugged, the settings of the controller return to the factory settings.

According to EU Directive 2006/66/EC, the battery may only be removed at the end of its life by a qualified person.

Installation of the universal electronic week temperature controller

The controller is recommended to be installed in a place that:

- has easy access,
- is free of curtains, shelves cabinets, etc.,
- allows free air circulation,
- is not exposed to direct sunlight,
- is not exposed to drafts (with open doors and windows),
- is not exposed to any other source of heat/cold,
- is not located on an outside wall,
- is at a height of 1.5 m above the floor.

Notice!

- universal electronic week temperature controller should be mounted in a flush-mounted box with a diameter of Ø60, made of plastic,
- the maximum length of the cable insulation removed must not exceed 8 mm,
- for cables with a cross-section of 1-2.5 mm²,
- the connection should be made in accordance with the diagram on page 3.

Wiring diagram

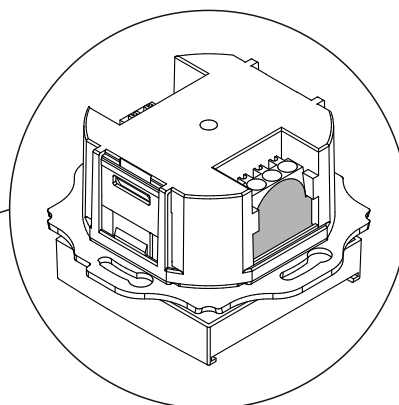
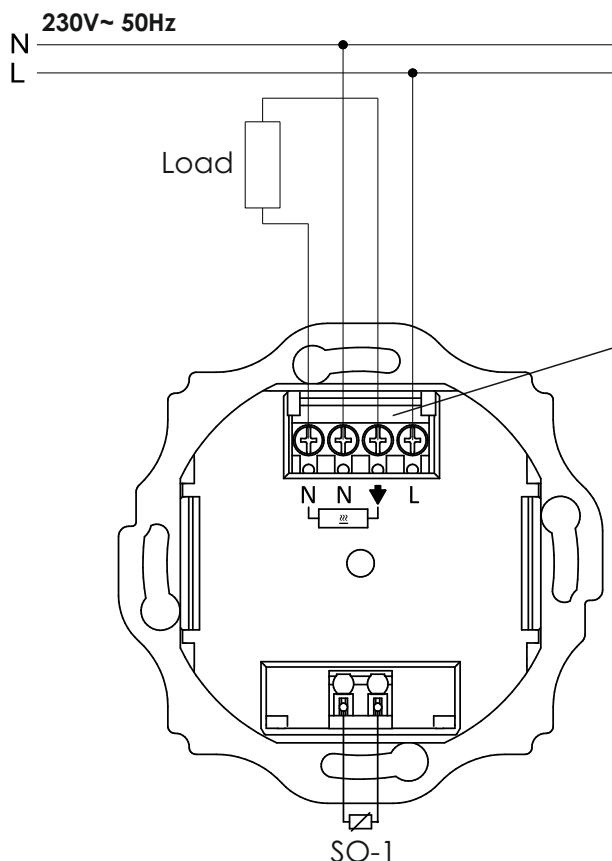

Notice!

The plastic tab should be installed in such a way as to provide insulation between the connections/wires and the mounting screws.

Probe SO-1 (accessory)

To insert or remove the flexible probe cable, press the white buttons under the cable.

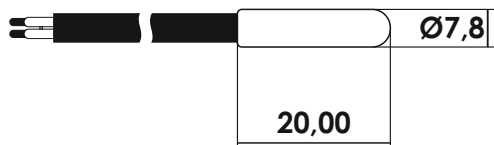

Probe resistance values (SO-1)

Temperature	Resistance
10 °C	66,8 kΩ
20 °C	41,3 kΩ
25 °C	33,0 kΩ
30 °C	26,3 kΩ
40 °C	17,0 kΩ
50 °C	11,3 kΩ

Universal electronic week temperature controller - components

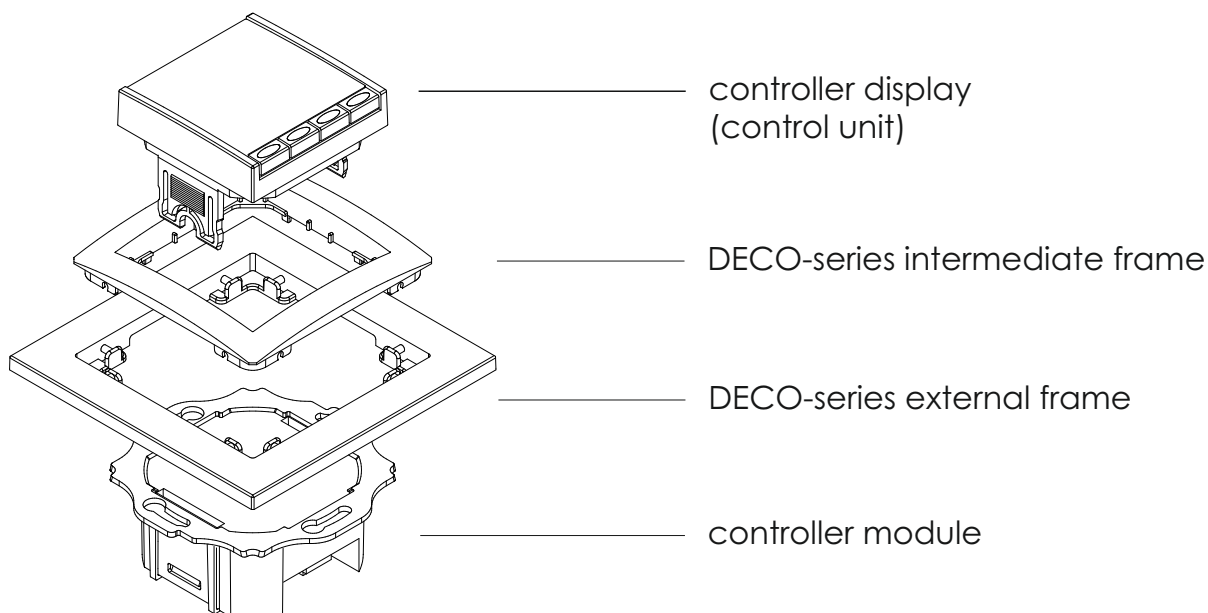

Operating mode selection

The universal electronic week temperature controller allows operation in the following three operating modes:

- ROOM - room temperature control,
- FLOOR - underfloor heating control,
- LIMITER - room temperature controller with limiter.

To select the appropriate mode:

1. Press the MENU button, then use the +/- buttons to move to the INSTALLERSETTING CHANGE APPLICATION DETAILS (confirm the selection with the OK button).
2. Using the +/- buttons, select code 7.
3. Select H1 - APPLICATION (the selection should be confirmed with the OK. button), using the +/- buttons, switch to the preferred mode of the ROOM, FLOOR or LIMITER (the selection should be confirmed with the OK button).
4. Depending on the mode selection, further steps should be carried out according to the instructions:
 - **ROOM - page 6,**
 - **FLOOR - page 9,**
 - **LIMITER - page 12,**
 - **functions and operation of the temperature controller for all modes (ROOM, FLOOR, LIMITER) - page 15.**

Notice!

If the mode is changed, the user and installer settings change to the default values.

Properties of the temperature controller (depending on the selected mode of operation):

- line text display for easy operation,
- display backlight (...DRT-3.1 white, ...DRT-3.1 blue),
- current time (setting year, month, day, time), - automatic switching of daylight saving time,
- max. 9 time intervals per day (separate during the entire day),
- default and customized time programs,
- optimal start (temperature will reach the set value),
- programmable also when the control unit (display) is detached,
- shutdown function, MENU button must be held for 10 seconds,
- vacation function with date setting (you can set the date from...to),
- energy consumption display (ON time * cost) for the last 2 days, week, 30 days, year,
- option to set energy cost after 1 hour,
- anti-frost protection,
- temperature can be set only within a limited range,
- access protection (unwanted override),
- operating language selection,
- PWM or ON/OFF control mode,
- minimum values of ON/OFF time and hysteresis set for ON/OFF control,
- possibility to set min. and max. floor temperature (applies to LIMITER mode),
- valve protection (applies to ROOM and LIMITER modes),
- adaptability to set valves in open or closed position (applies to ROOM and LIMITER modes),
- selectable heating or cooling function (applies to ROOM mode),
- measurement of room temperature by remote sensor (probe) or internal sensor (applies to ROOM mode),
- clock (Party) - specified temperature in a set time interval (applies to ROOM and FLOOR modes),
- floor temperature presented numerically (applies to FLOOR mode).

PROGRAMMING MANUAL - UNIVERSAL ELECTRONIC WEEK TEMPERATURE CONTROLLER - ROOM

Characteristics of the universal electronic week temperature controller - room

After proper installation and connection, the temperature controller automatically shows the time of day and room temperature. In AUTO operation mode, heating (cooling) will be automatically turned on, according to the programmed time and temperature. Program 1 is the program set by default. The room temperature is adjusted based on the temperature measurement taken by the internal sensor. The heating will turn on as the temperature drops below the level of the setpoint.

The week room temperature controller can be used to control the room temperature in combination with :

- thermal actuators, such as underfloor water heating or convector heaters,
- oil or gas radiators,
- circulation pumps,
- heat pumps,
- electric convector heaters, ceiling heating and storage heating.

Connecting a probe (SO-1)

To measure the room temperature, instead of an internal sensor, you can use a probe (SO-1). Probe selection can be made in the menu, see H1.

The probe should be placed in the electrical conduit (which will facilitate replacement if necessary). The probe can be extended using cables or connections for 230V to a maximum. 50 m. Avoid running the probe cables parallel to the power cables, such as in the cable duct.

Notice!

The probe wire may be under mains voltage.

Defined programs

The temperature controller has three defined programs for temperature control at specific time intervals. at the user's disposal. Program 1 is specified as standard. To select another program (see G1).

Program 1

Monday to Friday

Time allocation	1	2	3	4	5	6
Time	06:00	08:30	12:00	14:00	17:00	22:00
Temperature °C	21	18	21	18	21	15

Saturday and Sunday

Time allocation	1	2	3	4	5	6
Time	07:00	10:00	12:00	14:00	17:00	23:00/22:00*
Temperature °C	21	18	21	21	21	15

*23:00/22:00 = 23:00 on Saturday

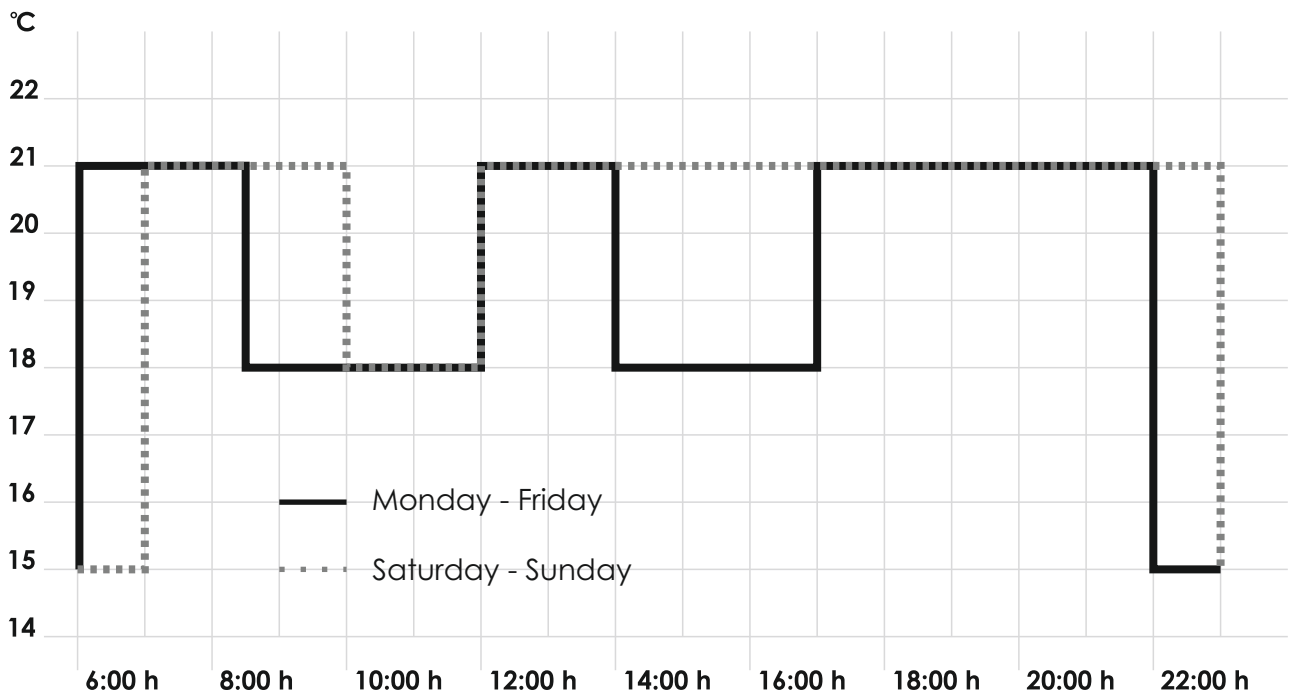

Program 2

Monday to Friday

Time allocation	1	2	3	4	5	6
Time	06:00	08:30	12:00	14:00	17:00	22:00
Temperature °C	21	18	21	18	21	15

Saturday and Sunday

Time allocation	1					2
Time	07:00					23:00/22:00*
Temperature °C	21					15

*23:00/22:00 = 23:00 on Saturday

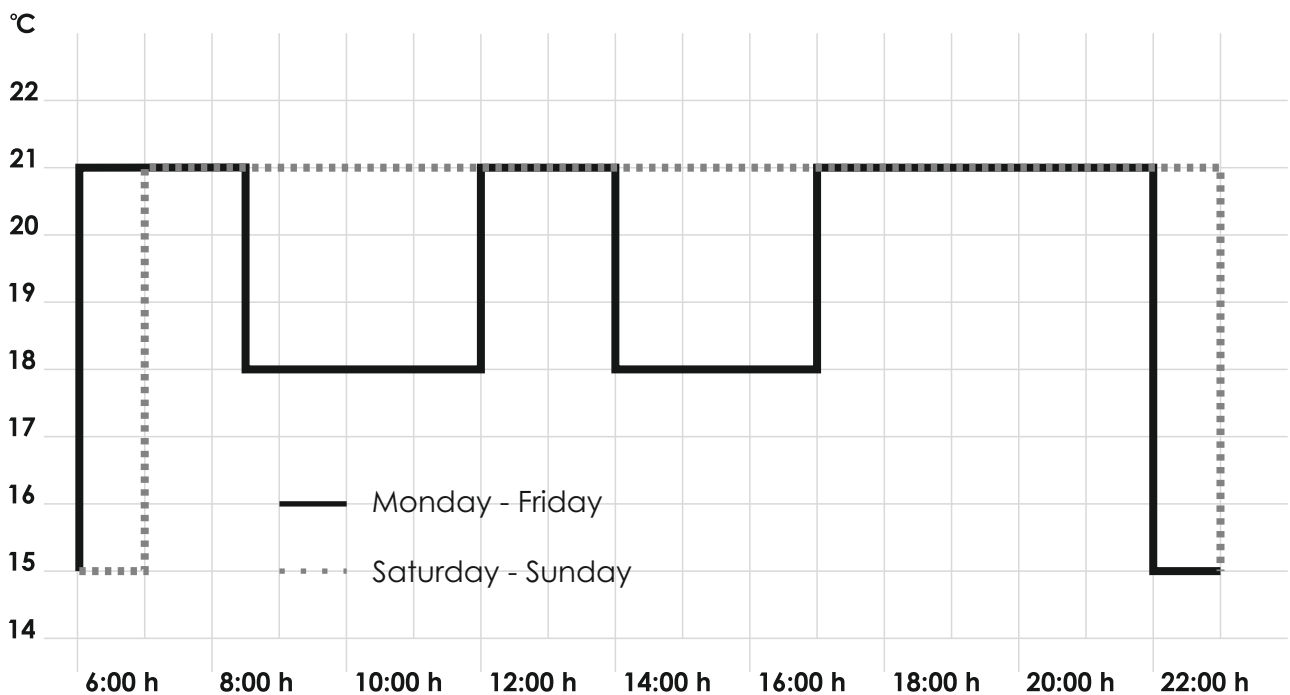

Program 3

Monday to Friday

Time allocation	1	2			3	4
Time	06:00	08:30			17:00	22:00
Temperature °C	21	18			21	15

Saturday and Sunday

Time allocation	1	2			3	4
Time	07:00	10:00			12:00	23:00/22:00*
Temperature °C	21	18			21	15

*23:00/22:00 = 23:00 on Saturday

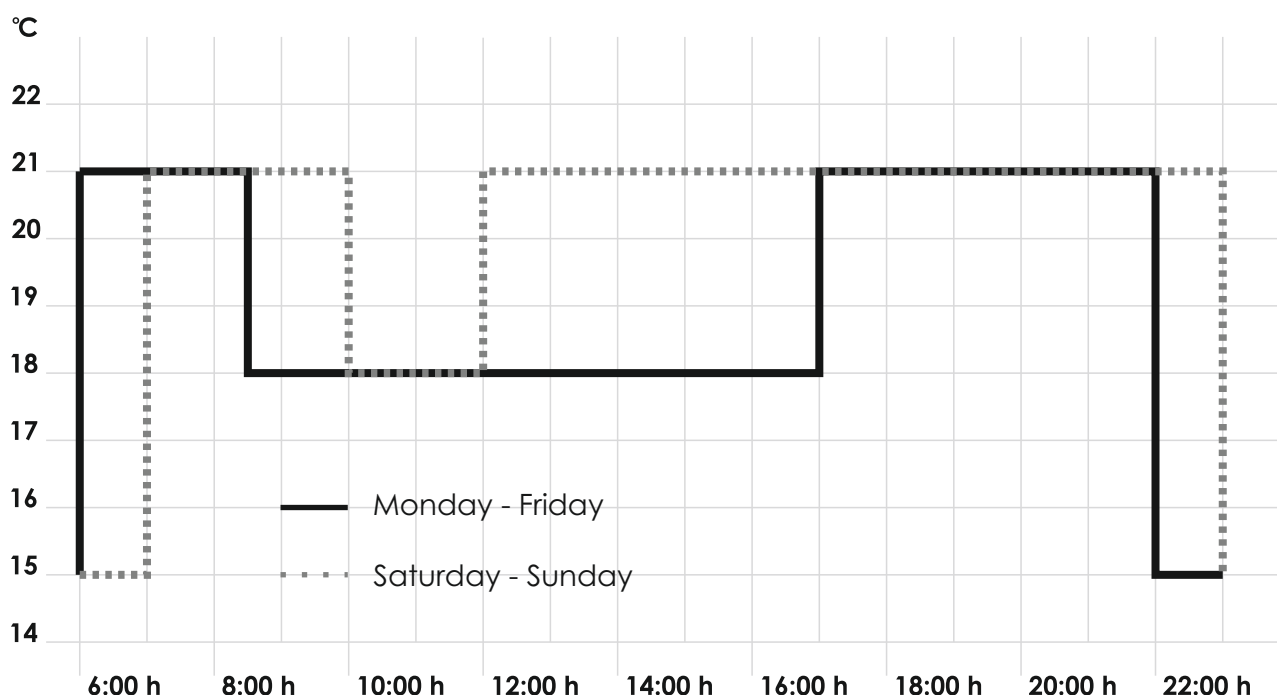

Notes on programming

- active settings automatically turn off without saving, three minutes after the last press. This will be followed by a return to the previous active mode, e.g. AUTO, MAN, etc.
- programming: set the value with the +/- buttons, and then press OK.
- in case of settings for the user and installer, the menu displays the numbers of the items listed in the manual, e.g., G1 for "program selection" or H2 for "control mode."

Troubleshooting

1. It's getting warm too late:
 - has the time interval and time been set correctly?
 - is "optimal start" enabled? (See H7)
 - did the controller have enough (a few days) to adapt to the characteristics of the room?
 - is the automatic daylight saving time change function enabled? (see G5)
2. The controller does not accept any changes.
 - has access protection been activated? (see G6)
3. The temperature setting range is limited.
 - are temperature restrictions enabled? (see G7)
4. The temperature display does not change:
 - is the display of the required target temperature activated? (see G10)

PROGRAMMING MANUAL - UNIVERSAL ELECTRONIC WEEK TEMPERATURE CONTROLLER - FLOOR

Characteristics of the universal electronic week temperature controller - floor

After proper installation and connection, the temperature controller automatically shows the time of day and room temperature. In AUTO operation mode, the heating will be automatically turned on, according to the programmed time and temperature. Program 1 is the default setting, the temperature is adjusted based on the floor temperature, and the heating will turn on automatically when the floor temperature drops below the level set on the thermostat and turn off when the specified temperature is reached.

The week temperature controller for underfloor heating can be used to control the temperature in combination with:

- direct heating,
- underfloor heating system.

Connecting the probe (SO-1)

The probe should be placed in the electrical conduit (which will facilitate replacement if necessary). The probe can be extended using cables or connections for 230V to a maximum. 50 m. Avoid running the probe cables parallel to the power cables, such as in the cable duct.

Notice!

The probe wire may be under mains voltage.

Defined programs

The temperature controller has three defined programs for temperature control at specific time intervals, at the user's disposal. Program 1 is specified as standard. To select another program (see G1).

Program 1

Monday to Friday

Time allocation	1	2			3	4
Time	06:00	08:00			19:00	22:00
Temperature °C	28	18			28	15

Saturday and Sunday

Time allocation	1	2			3	4
Time	08:00	10:00			19:00	22:00
Temperature °C	28	18			28	15

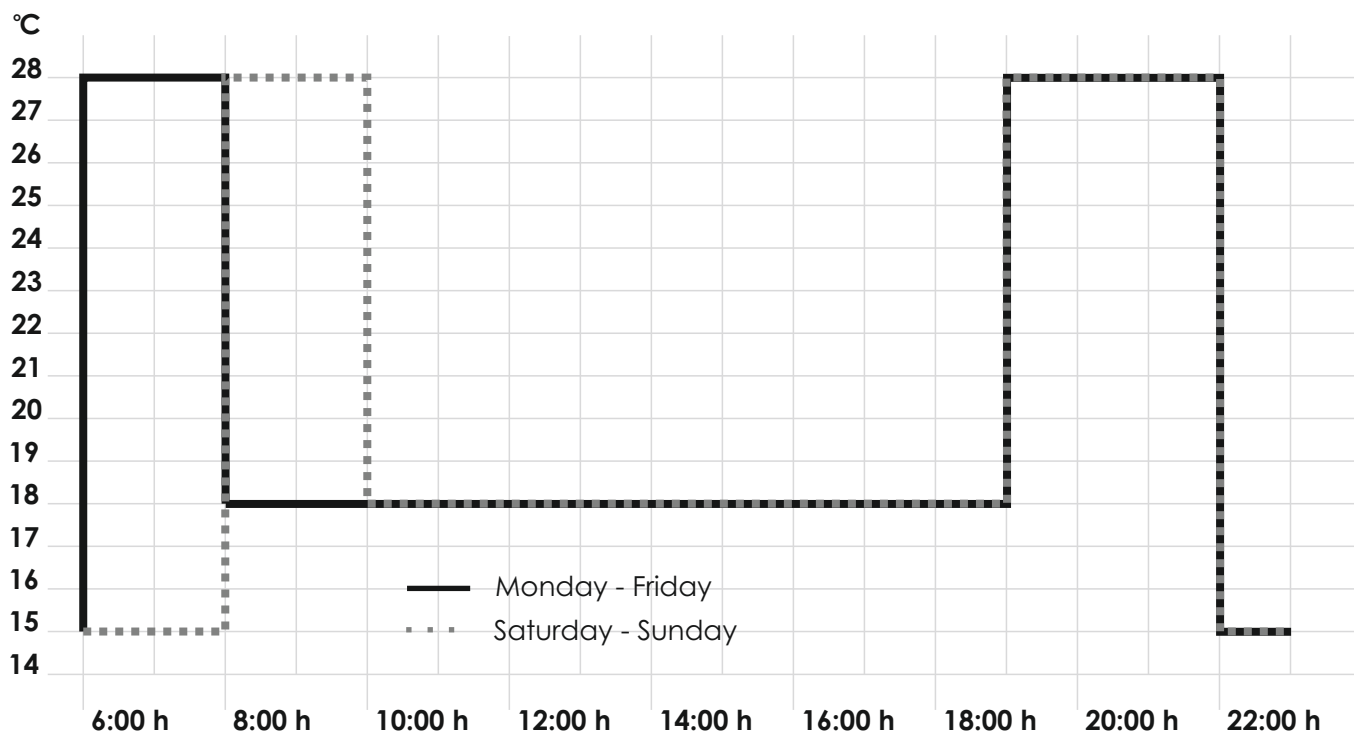

Program 2

Monday to Friday

Time allocation	1	2	3	4	5	6
Time	06:00	08:00	12:00	14:00	19:00	22:00
Temperature °C	28	18	28	18	28	15

Saturday and Sunday

Time allocation	1	2	3	4	5	6
Time	08:00	10:00	12:00	14:00	19:00	22:00
Temperature °C	28	18	28	18	28	15

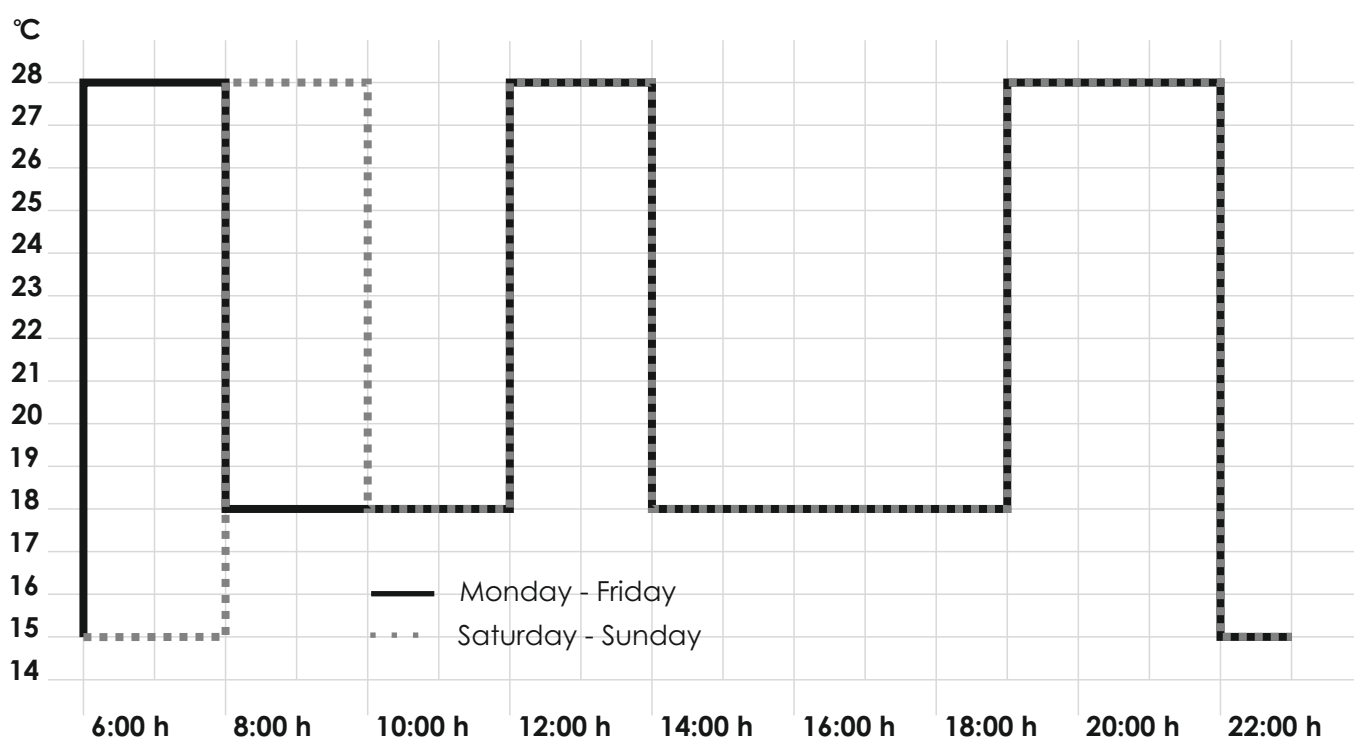

Program 3

Monday to Friday

Time allocation	1	2				3
Time	11:00	13:00				22:00
Temperature °C	28	18				15

Saturday and Sunday

Time allocation	1	2			3	4
Time	08:00	10:00			19:00	22:00
Temperature °C	28	18			28	15

*23:00/22:00 = 23:00 on Saturday

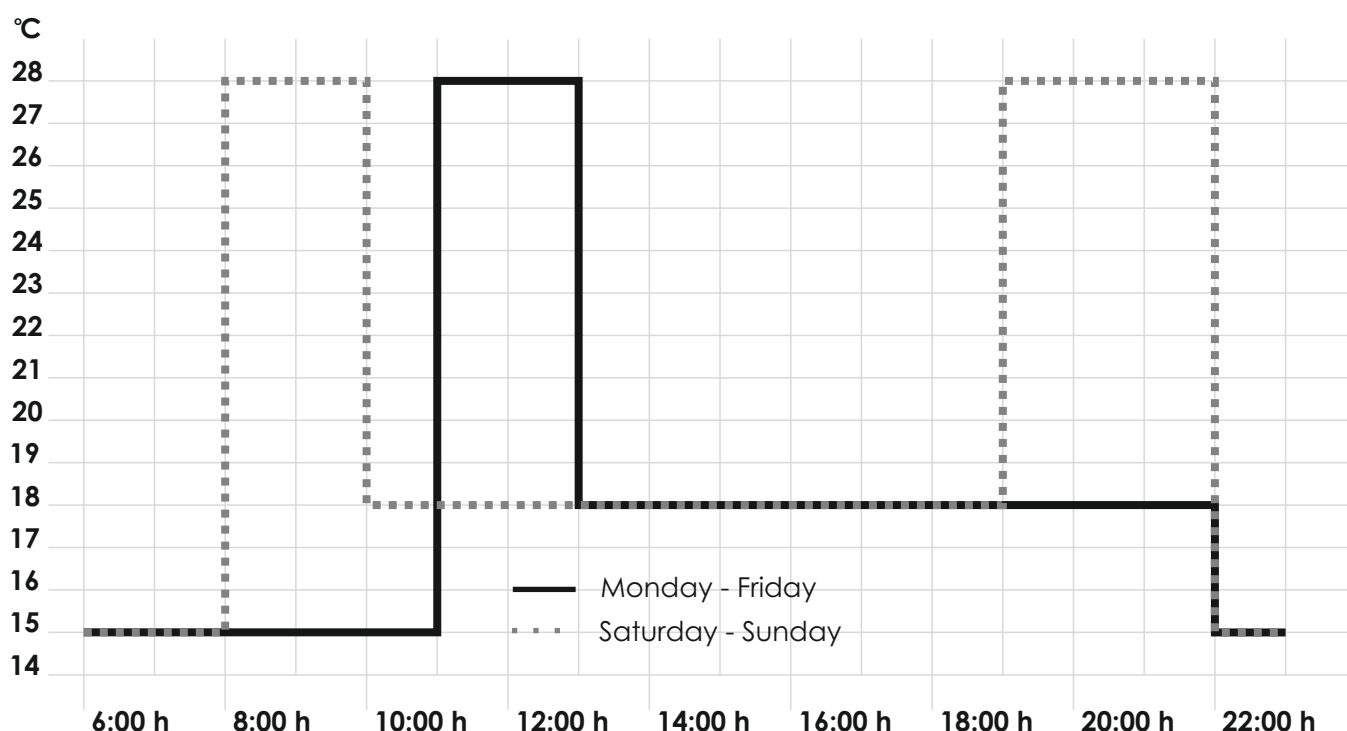

Notes on programming

- active settings automatically turn off without saving, three minutes after the last press. This will be followed by a return to the previous active mode, e.g. AUTO, MAN, etc.
- programming: set the value with the +/- buttons, and then press OK.
- in case of settings for the user and installer, the menu displays the numbers of the items listed in the manual, e.g., G1 for "program selection" or H2 for "control mode".

Troubleshooting

1. It's getting warm too late:
 - has the time interval and time been set correctly?
 - is "optimal start" enabled? (See H7)
 - did the controller have enough (a few days) to adapt to the characteristics of the room?
 - is the date set correctly?
 - is the automatic daylight saving time change function enabled? (see G5)
2. The controller does not accept any changes.
 - has access protection been activated? (see G6)
3. The temperature setting range is limited.
 - are temperature restrictions enabled? (see G7)
4. The temperature display does not change:
 - is the display of the required target temperature activated? (see G10)

PROGRAMMING MANUAL - UNIVERSAL ELECTRONIC WEEK TEMPERATURE CONTROLLER - LIMITER

Characteristics of the universal electronic week temperature controller - limiter

After proper installation and connection, the temperature controller automatically shows the time of day and room temperature. In AUTO operation mode, the heating will be automatically turned on, according to the programmed time and temperature. Program 1 is the program set by default. The room temperature will be adjusted and the floor temperature will be limited (measured by the remote sensor). The heating will turn on automatically as the temperature drops below the setpoint.

In the case of the "Minimum floor temperature" function, the heating will turn on if the floor temperature falls below the set minimum value. This is the case even when the room temperature is too high.

In the case of the "Maximum floor temperature" function, the heating will turn off if the floor temperature exceeds the set maximum value. This is the case even when the room temperature is too low.

The week temperature controller for underfloor heating can be used to control the temperature in combination with :

- electric floor heating systems, where the floor temperature must be within a certain range of values,
- hot water-fed floor heating systems in combination with thermal actuators.

Probe connection (SO-1)

When using the "LIMITER" mode of operation, the temperature controller requires using a probe (SO-1). The probe should be placed in the electrical conduit (which will facilitate replacement if necessary). The probe can be extended using cables or connections for 230V to a maximum. 50 m. Avoid running the probe cables parallel to the power cables, such as in the cable duct.

Notice!

The probe wire may be under mains voltage.

Defined programs

The temperature controller has three defined programs for temperature control at specific time intervals. at the user's disposal. Program 1 is specified as standard. To select another program (see G1).

Program 1

Monday to Friday

Time allocation	1	2	3	4	5	6
Time	06:00	08:30	12:00	14:00	17:00	22:00
Temperature °C	21	18	21	18	21	15

Saturday and Sunday

Time allocation	1	2	3	4	5	6
Time	07:00	10:00	12:00	14:00	17:00	22:00/23:00*
Temperature °C	21	18	21	21	21	15

*23:00/22:00 = 23:00 on Saturday

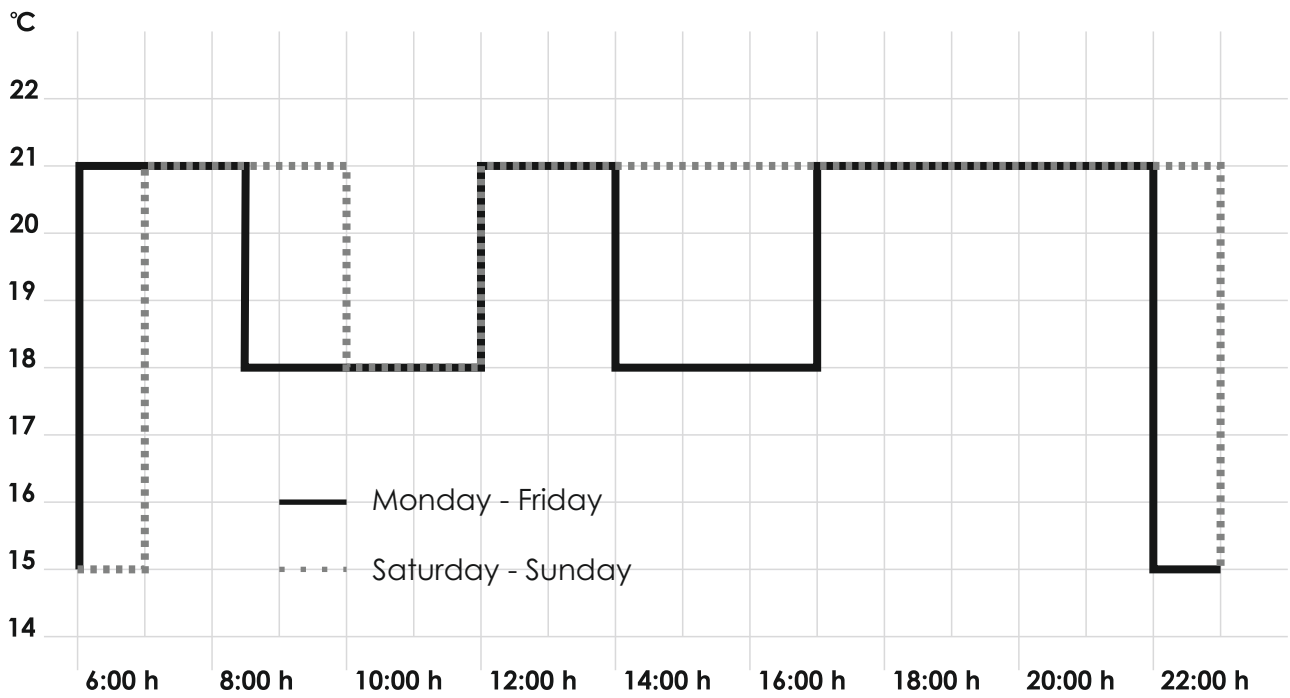

Program 2

Monday to Friday

Time allocation	1	2	3	4	5	6
Time	06:00	08:30	12:00	14:00	17:00	22:00
Temperature °C	21	18	21	18	21	15

Saturday and Sunday

Time allocation	1					2
Time	07:00					23:00/22:00*
Temperature °C	21					15

*23:00/22:00 = 23:00 on Saturday

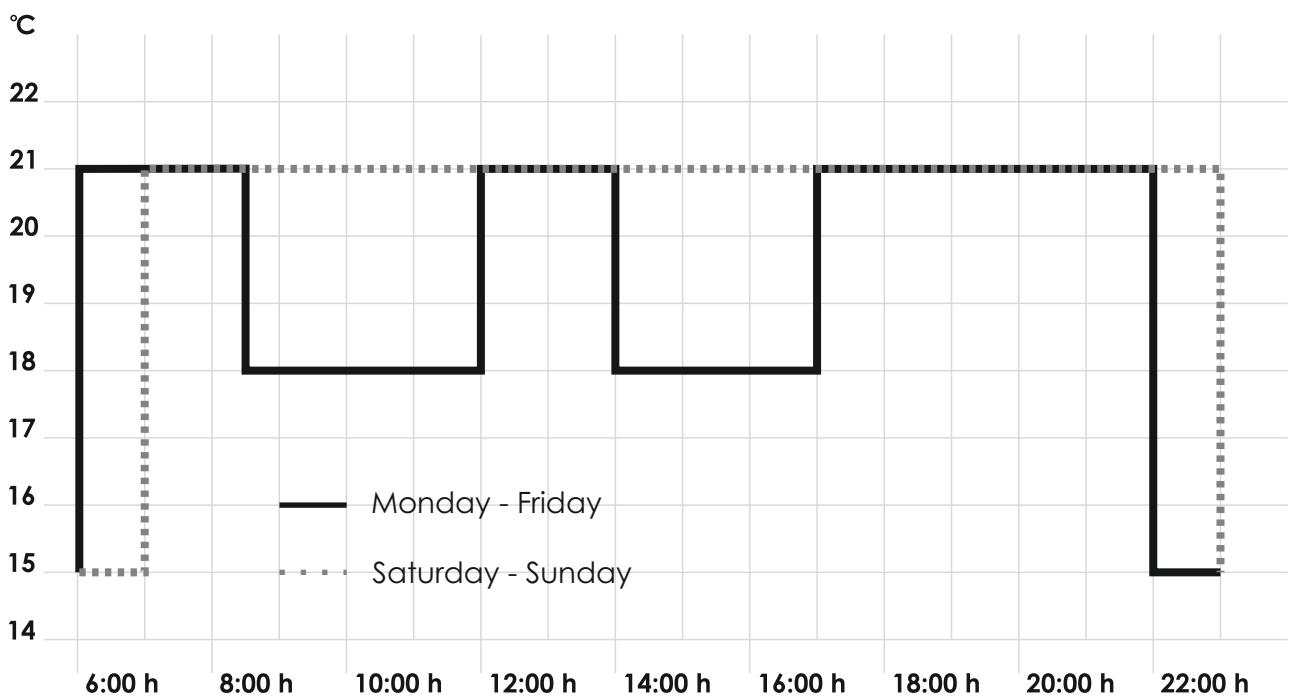

Program 3

Monday to Friday

Time allocation	1	2			3	4
Time	06:00	08:30			17:00	22:00
Temperature °C	21	18			21	15

Saturday and Sunday

Przydział czasowy	1	2			3	4
Czas	07:00	10:00			12:00	23:00/22:00*
Temperature °C	21	18			21	15

*23:00/22:00 = 23:00 on Saturday

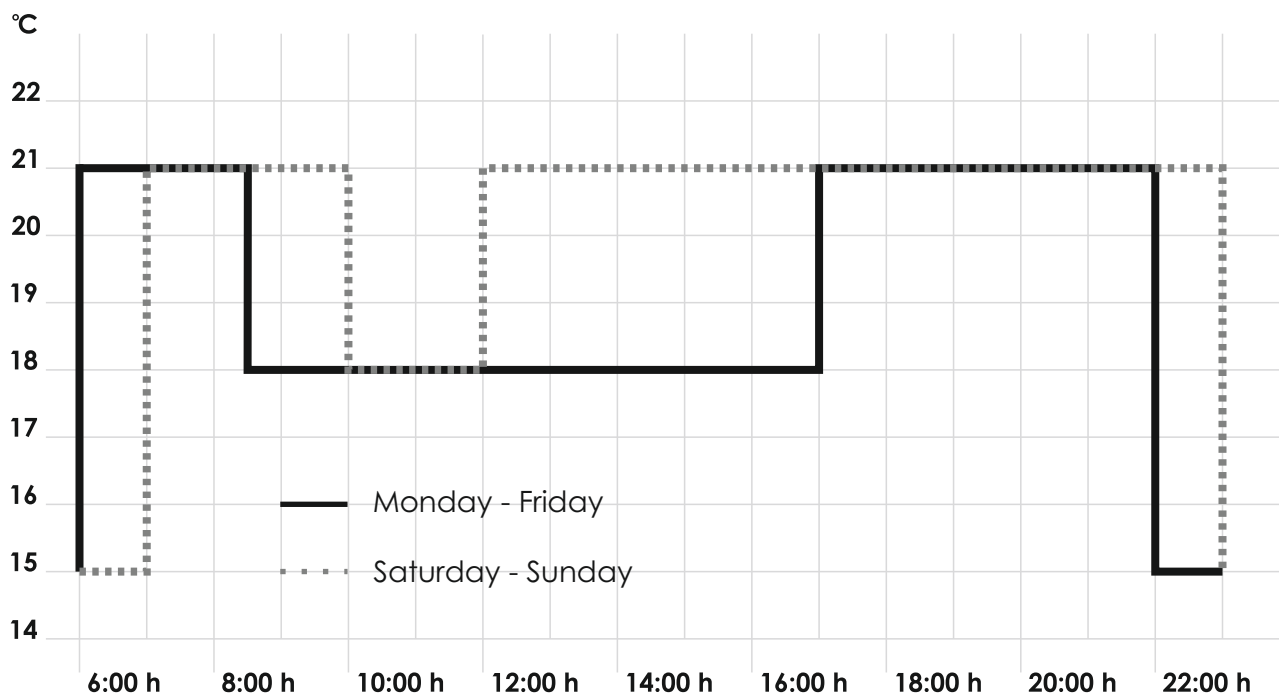

Notes on programming

- active settings automatically turn off without saving, three minutes after the last press. This will be followed by a return to the previous active mode, e.g. AUTO, MAN, etc. - programming: set the value with the +/- buttons, and then press OK.
- in case of settings for the user and installer, the menu displays the numbers of the items listed in the manual, e.g., G1 for "program selection" or H2 for "control mode."

Troubleshooting

1. It's getting warm too late:
 - has the time interval and time been set correctly?
 - is "optimal start" enabled? (See H7)
 - did the controller have enough (a few days) to adapt to the characteristics of the room?
 - is the automatic daylight saving time change function enabled? (see G5)
2. The controller does not accept any changes.
 - has access protection been activated? (see G6)
3. The temperature setting range is limited.
 - are temperature restrictions enabled? (see G7)
4. The temperature display does not change:
 - is the display of the required target temperature activated? (see G10)
5. The room heats up too slowly - the floor temperature can be limited by the "Maximum floor temperature" function of the controller. (See H)
6. The room heats up too quickly - the floor temperature can be limited by the "Minimum floor temperature" function of the controller. (see H)

DESCRIPTION OF FUNCTIONS AND OPERATION OF THE UNIVERSAL ELECTRONIC WEEK TEMPERATURE CONTROLLER - FLOOR, ROOM, LIMITER

Language selection

For products that do not have a defined language, the user must set their language by pressing: **ENGLISH +/-** to select the language and then OK to confirm the selection, the screen will display AUTO mode (to change the language back, select G14 in the MENU). The foregoing settings are only required to be entered when the device is first started or restarted.

How to use the temperature controller?

- changing the temperature (until the next time interval),
see: **buttons, +/- in AUTO**
- temperature control according to specific properties,
see: **main menu, AUTO**
- fixed temperature setting (manual operation = MAN),
see: **main menu, MAN**
- temperature setting for a specific number of hours,
see: **main menu, TIMER**
- temperature setting for a specific day,
see: **main menu, HOLIDAY**
- setting a separate program for specific days,
see: **main menu, AT HOME - TEMP FOR EXTRA DAYS**
- adjusting the controller to personal needs,
see: **main menu, USER - SETTING CHANGE BEHAVIOUR**
- adjust the controller to the needs of the application,
see: **main menu, INSTALLER - SETTING CHANGE APPLICATION DETAILS**

Buttons

Buttons	Function	To confirm / activate
+/- in AUTO (-)	Periodically change the temperature to the next time interval, displaying OK as minus AUTO (AUTO-). The first time you press it, the set temperature will be displayed, and after pressing it again, its value will change with every press	OK
+/- in MENU	Go +/- in MENU	
OK	Press to confirm your setting/selection	
INFO	Additional information in AUTO, MAN, TIMER, HOME is displayed. To cancel, press the button again	
MENU	Enter MENU, use +/- buttons to move next	
MENU	One step back (undo)	
MENU for 10 seconds	Turning the heating off. OFF will be displayed later, see G4.	

	Main menu		To confirm / activate
A	MENU	Use the +/- buttons to move to the desired menu item.	
B	AUTO	The temperature will automatically set according to the time and temperature of the current program, see G1. Use the +/- buttons to change the temperature values up to the next time interval.	OK
C	MAN	The temperature will be constantly monitored, to set it, use the +/- buttons and confirm the changes with the button.	OK
D	TIMER	The temperature will be controlled temporarily according to the time and temperature settings in the menu. After this time, the previous mode of operation will be restored.	OK
E	HOLIDAY	Allows you to set both the temperature and the number of days before the initial value is restored. The HOLIDAY mode turns on at 0:00 on the first day and turns off at 24:00 on the last day. The AUTO function is active before the HOLIDAY mode is activated. While waiting for the vacation start date, you can select other modes of operation (AUTO, MAN, TIMER, AT HOME). The INFO function will provide detailed information about the upcoming vacation. In this situation, the HOLIDAY mode will start automatically when the start date occurs. After the vacation period, the previous mode of operation will be restored.	OK
F	AT HOME (temperature on additional days)	The temperature will set after this set program (regardless of AUTO). The temperature will apply on all days. The primary settings correspond to the program starting from Monday. The user closes the program by selecting, e.g. AUTO. Usage: time off, vacation, illness, etc.	OK
G	USER (adjusting the operation mode)	Adaptation to the user's lifestyle.	OK
H	INSTALLER (changing the operation mode)	Adjust the temperature settings to the heating system (function available for installers only).	OK

G	Settings: USER – CHANGE BEHAVIOR	Customization to meet the personal needs of the user	Default settings 0 = value range		
			ROOM	FLOOR	LIMITER
1	Program selection	Selecting a default program, see "Defined programs" (if another program is selected, the settings will not be saved).	P1 P1, P2, P3	P1 P1, P2, P3	P1 P1, P2, P3
2	Event setting	Change the time and temperature on selected days of the active program, see "Defined programs". Each time interval can be reduced to the previous one or to 00:00. Each time interval can be extended until 23:50, after which ->>> will be displayed, indicating that the time interval applies to the next day. If you press the +/- button during ->>>, you can set the time interval again. A total of as many as 9 time intervals can be set. The first digit indicates the current time interval, such as 3. 12:00-14:00 means the third time interval. Time intervals can also be saved as time blocks by selecting preset days (Monday – Friday, Saturday/Sunday, Monday – Sunday). To finish programming, press the MENU button again. Selecting a default program, see "Defined programs" (if another program is selected, the settings will not be saved).	Yes, like the G1 selected	Yes, like the G1 selected	Yes, like the G1 selected
3	Clock setting	Setting the current date and time.			
4	Off heating permanent	The adjustment will be turned off, OFF will be displayed. The controller will remain energized. Anti-frost protection can be triggered when activated, see H6. Turning on again is possible by activating AUTO mode or by pressing the MENU button for 10 s. AUTO mode is activated when switching on again using the MENU button or through the menu.	NO	NO	NO
5	Summer / winter change	Selecting automatic daylight saving time switching.	YES	YES	YES
6	Key lock	Protecting the controls against unauthorized use. Reactivated using the code = 93.	NO	NO	NO
7	Temp limit min / max temp	Limits the temperature range that can be set by the user. Setting is not possible if the two limits are identical. Affects the following modes: AUTO, MAN, VACATION, CLOCK, HOME, programming. The active program/operation mode will not be changed automatically.	5; 30°C	5; 30°C	5; 30°C

G	Settings: USER – CHANGE BEHAVIOR	Customization to meet the personal needs of the user	Default settings 0 = value range		
			ROOM	FLOOR	LIMITER
8	Cost / hr of energy	Displays the approximate energy cost per hour (pennies/hour), can be set. To use this function as an hour meter, set a cost of 100 pennies/hour.	100 (1...999)	100 (1...999)	100 (1...999)
9	Energy - consumption to date	The approximate cost of energy in the controlled area will be displayed, for the last: 2 days, weeks, 30 days, a year. On the current day, the calculation is performed in real time. When exceeded, 9999 will be displayed. This function mainly applies to electric heating. Calculation: heater operating time x energy cost per hour – see above. For reset, see H9.			
10	Set temp to read	The required temperature will be displayed instead of the room temperature.	NO	NO	NO
11	Adjust temp	Set the temperature to the user's personal requirements.	0 (-5,0...+5,0)	NOT APPLICABLE	0 (-5,0...+5,0)
12	Number for floor temp	The floor temperature will be displayed as an ID number.	NOT APPLICABLE	NO	NOT APPLICABLE
13	Blacklight	Continuous, off, or short when the button is pressed.	SHORT (SHORT, OFF)	SHORT (SHORT, OFF)	SHORT (SHORT, OFF)
14	Language	Language selection.			
15	Info	Display the type and version of the controller.			
16	Reset user - settings only	Only USER settings will be restored to the factory settings. The energy meter will not be reset, in order to reset the meter, see H9.	NO	NO	NO

H	Settings: INSTALLER - CHANGE APPLICATION	Adjust temperature settings to meet application requirements (only for installers)	Default settings 0 = value range		
			ROOM	FLOOR	LIMITER
0	Code	For these settings, enter a code (=7) that is valid for one hour.			
1	Application	The controller is suitable for use in the heating system listed in the right column. You can choose whether to use the remote sensor.	ROOM	FLOOR	LIMITER
2	Control mode	You can select the type of PWM or ON/OFF signal. For PWM, you can set the cycle time (in minutes). Minimum ON/OFF time = 10% of cycle time. Use a short time for heating systems with fast response times, and a longer time for slow-response systems. For ON/OFF, you can select: - Hysteresis OFF - no hysteresis setting, even in the case of very small temperature changes, the relay will switch for the time specified below. - Minimum ON/OFF time (the relay will be in ON or OFF mode at least for this time).	PWN/10 (/10...30) OFF (OFF, 0,1...5,0) 10min (1...30)	PWN/10 (/10...30) OFF (OFF, 0,1...5,0) 10min(1...30)	PWN/10 (/10...30) OFF (OFF, 0,1...5,0) 10min (1...30)
3	Min/max floor temp	Limits the temperature of the floor. Possible selection: - minimum floor temperature that does not drop below the set temperature (OFF = no limit); Min-temp. = 21°C, the floor temperature does not drop below 21°C, even if the room is too warm. - maximum floor temperature that does not rise above this set temperature (OFF = no limit); Max-temp. = 35°C, the floor temperature does not exceed 35°C, even if the room is too cold. If one of these restrictions is not needed, set it to OFF.	NOT APPLICABLE	NOT APPLICABLE	OFF (OFF, 10... Tmax) 35°C (OFF, Tmin...40)
4	Heating or cooling	HEATING: The controller operates in HEAT mode. REFRIGERATION: The controller operates in COOLING mode. Conditions: - cooling is only possible with the setting (H1) = ROOM, - anti-frost protection (H6) = NO (cannot be activated), - optimal start (H7) = NO (cannot be activated), - in case of error = no cooling, - time interval and temperature settings are the same as in HEAT mode (see G2), - only for the ON/OFF control method.	Heating (heating, cooling)	NOT APPLICABLE	NOT APPLICABLE
5	Valve protection	The output relays will be activated at the specified time each day, at 10:00 am.	3 min (OFF, 1...10)	NOT APPLICABLE	3 min (OFF, 1...10)

H	Settings: INSTALLER - CHANGE APPLICATION	Adjust temperature settings to meet application requirements (only for installers)	Default settings 0 = value range		
			ROOM	FLOOR	LIMITER
6	Frost protection	Anti-frost protection limit temperature setting. Turning on in the OFF mode, the temperature will be adjusted to this value.	5°C (OFF, 5...30)	5°C (OFF, 5...30)	5°C (OFF, 5...30)
7	Optimum start	The temperature will reach the setpoint at the time specified in the program. AUTO mode will be displayed in the previous compartment.	YES	NO	YES
8	Valves normally open	If open valves must be normally used.	NO	NOT APPLICABLE	NO
9	Energy counter reset	The energy meter will be reset to 0.	NO	NO	NO
10	Floor temp display	The temperature measured by the probe will be displayed (for service purposes).		NOT APPLICABLE	
11	Reset all	All settings, both installer and user settings, will be restored to factory default.	NO	NO	NO

Errors

In this situation, "Err" will be flashing on the screen, possibly indicating the following error:

1. CONFIGURATION - the display and module do not match:

- use only suitable parts,
- turn the power off and on.

2. COMMUNICATION - communication error between the display and the power module:

- remove the upper part and reconnect, - turn the power off and on.

3. EXTERNAL SENSOR (PROBE)

- remote sensor error - sensor replacement - measurement span exceeded.

In case of any of the foregoing errors, heating will be on for 30% of the time.

In case of the ROOM mode of operation:

if H4 = HEAT: heating will be on for 30% of the time,

if H4 = COOL: no cooling.